

# GX 270

*Horizontal shaft gasoline (petrol) engine*



*Moteur à essence à arbre de prise de force horizontal*

*Benzinmotor mit horizontaler Kurbelwelle*

*Motore a benzina ad albero orizzontale*

*Bensinmotor med horisontell axel*

*Benzinmotor met horizontale uitgaande as*

# GX 270

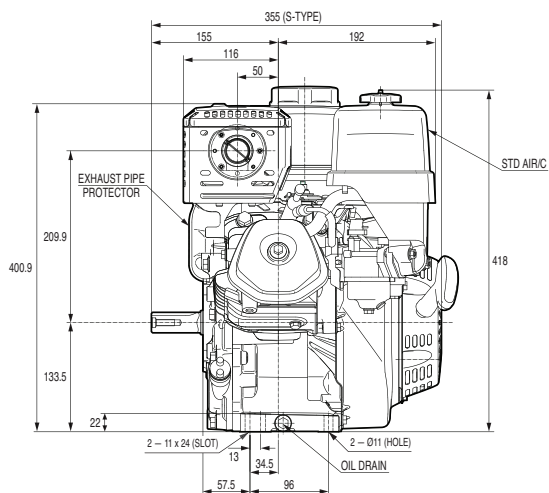
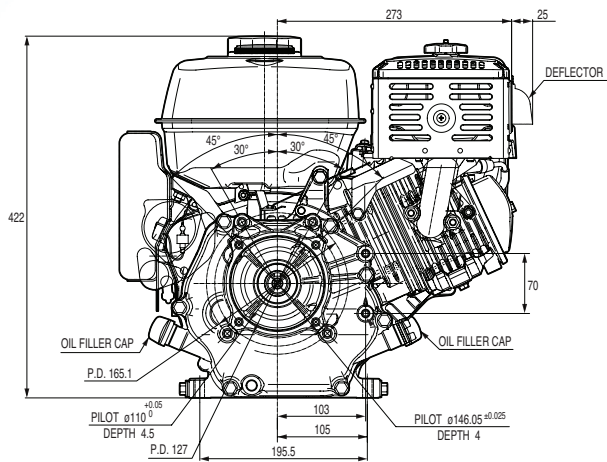
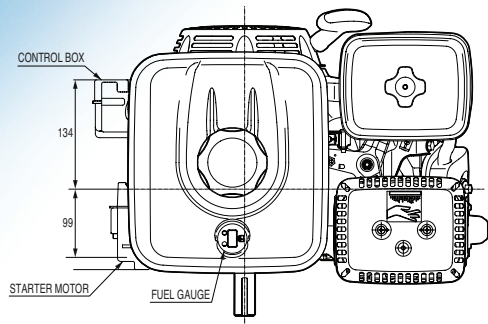
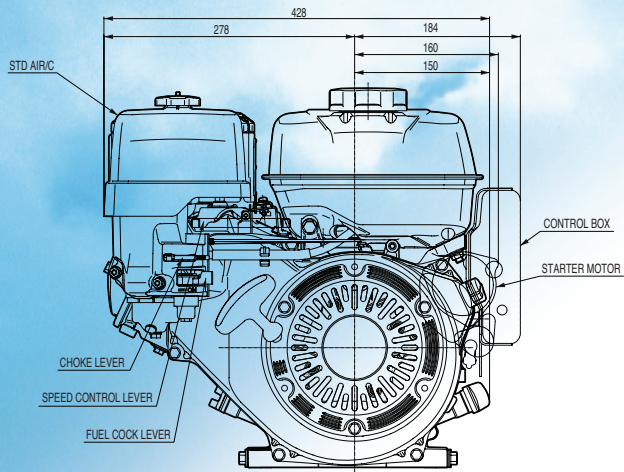

## REDUCTION TYPES

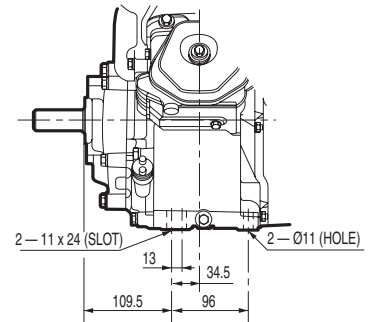
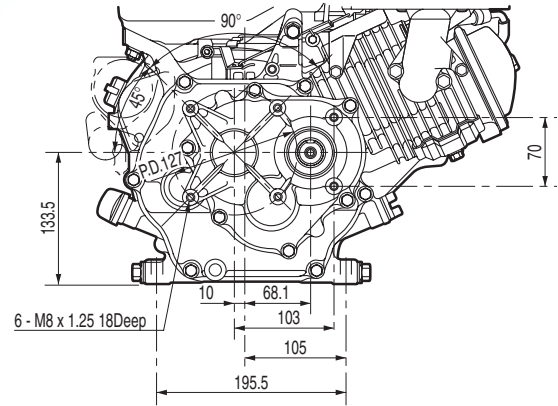

## 1/2 REDUCTION 1/2 REDUCTION WITH CLUTCH

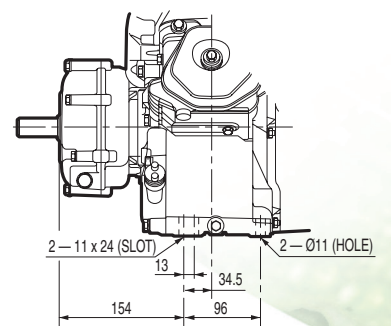
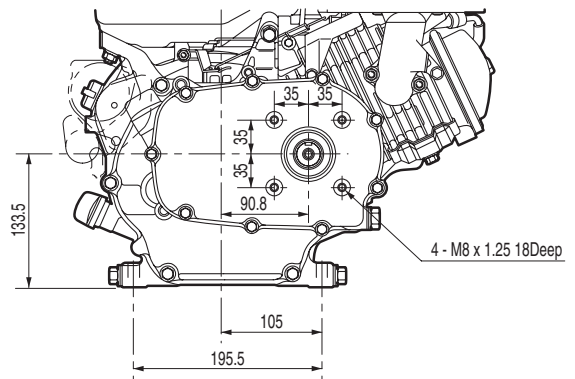

**Dimensions** Unit: mm (in.)

**STANDARD TYPE**

**PTO SHAFT DIMENSIONS**

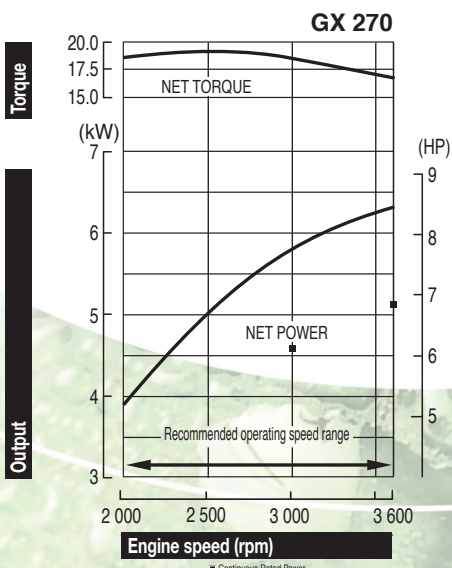
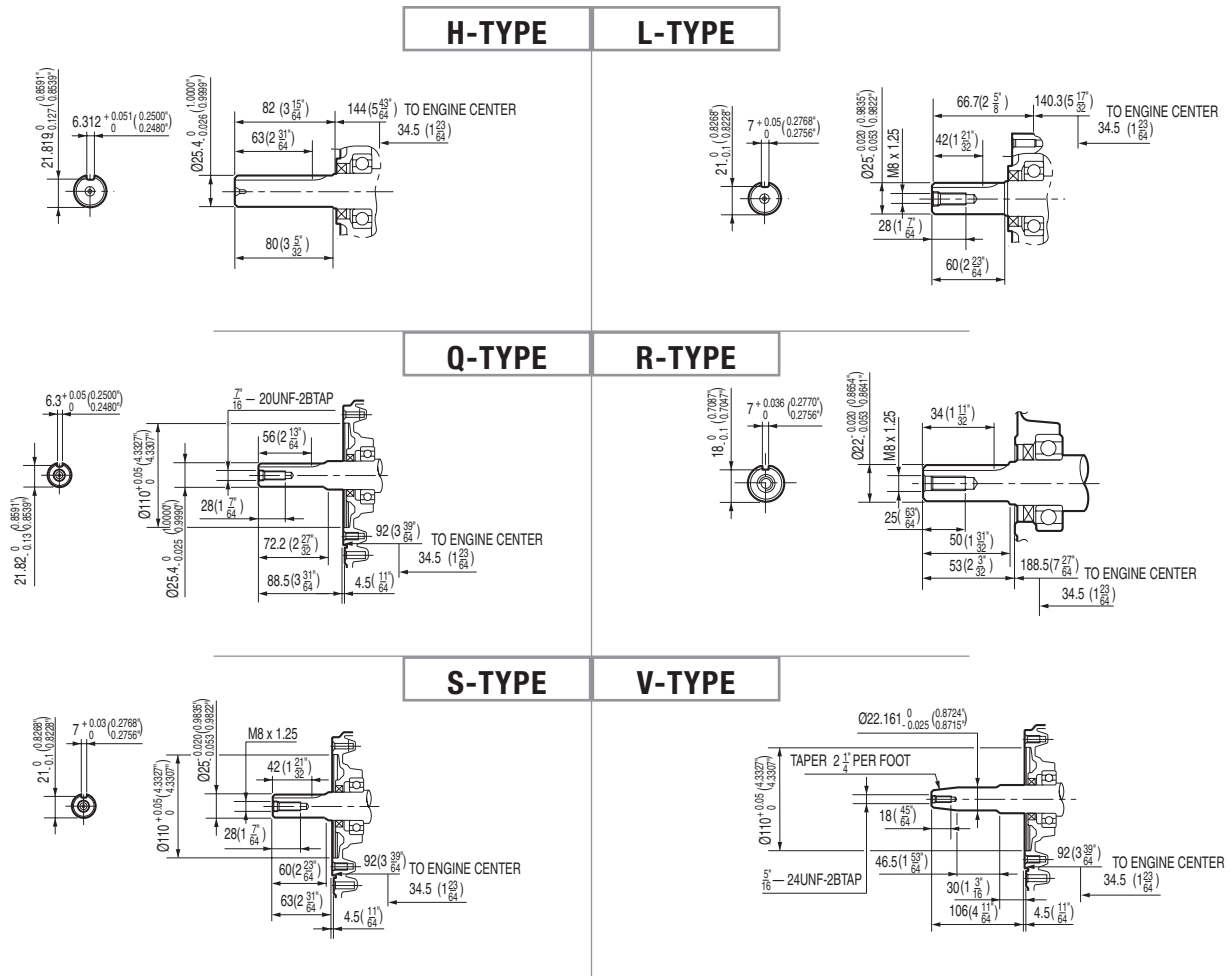

The power rating of the engine indicated in this document is the net power tested on a production engine for the engine model and measured in accordance with SAE J1349 at a specified rpm. Mass production engines may vary from this value. Actual power output for the engine installed in the final machine will vary depending on numerous factors, including the operating speed of the engine in application, environmental conditions, maintenance, and other variables.

La puissance du moteur indiquée dans ce document est une puissance nette obtenue par l'essai d'un moteur de série selon la norme SAE J 1349 à une vitesse de rotation donnée. La puissance d'un autre moteur de production peut être différente de cette valeur indiquée. La puissance réelle d'un moteur installé sur une machine dépendra de différents facteurs comme la vitesse de rotation, les conditions de température, d'humidité, de pression atmosphérique, de maintenance et autres.

Die Leistungsangabe der in diesem Dokument aufgeführten Motoren ist die Netto-Leistung gemäß SAE J1349, getestet bei einer definierten Drehzahl an einem Produktionsmotor. Bei Motoren aus Serienproduktion kann der Wert abweichen. Die Leistungsabgabe in einem Fertigergerät weicht, bedingt durch unterschiedliche Faktoren, wie Motordrehzahl in der Applikation, Umwelteinflüsse, Grad der Instandhaltung und andere Einflüsse ab.

La potenza indicata in questo documento, è la potenza netta rilevata su questo modello di motore in fase di produzione, ed è stata misurata secondo la procedura SAE J1349 ad un numero di giri specifico. Nella produzione di massa si possono riscontrare variazioni rispetto a questi valori. La potenza del motore installato nella macchina può dipendere da numerosi fattori, incluso il numero di giri al quale il motore è impiegato, le condizioni ambientali, dal livello di manutenzione ed altre variabili.

De bepaling van het vermogen van de motor, vermeld in dit document, is het netto vermogen getest op een productiemotor en gemeten in overeenstemming met SAE J1349 aan een specifieke t/min. Motoren van massaproductie kunnen van deze waarde variëren. Het werkelijke vermogen van de geïnstalleerde motor in het eindproduct kan afwijken, afhankelijk van talrijke factoren, zoals de operationele snelheid van de motor in een applicatie, omgevingsfactoren, onderhoud en andere variabelen.

Den i detta dokument nämnda motors effekt, är uppmätt i netto effekt. I enlighet med mätmetoden SAE J1349. Massproducerade motorer kan avvika från nämnda värde. Den faktiska effekten för varje motor kan variera beroende på bl a, varvtal, yttre omgivning, underhåll, typ av applikation, mm.

## Specifications

Model GX 270	
Engine type	Air cooled 4-stroke OHV petrol engine, 25° inclined cylinder, horizontal shaft, cast iron sleeve
Bore x stroke	77 x 58 mm
Displacement	270 cm <sup>3</sup>
Compression ratio	8.5 : 1
Net power	6.3 kW (8.4 HP) / 3 600 rpm
Cont. rated power	4.6 kW (6.2 HP) / 3 000 rpm 5.1 kW (6.8 HP) / 3 600 rpm
Max. net torque	19.1 Nm / 1.94 kgfm / 2 500 rpm
Ignition system	Digital CDI with variable ignition timing
Starting system	Recoil starter (electric start optional)
Fuel tank capacity	5.3 l
Fuel cons. at cont. rated power	2.4 L/hr - 3 600 rpm
Engine oil capacity	1.1 l
Dimensions (L x W x H)	381 x 428 x 422 mm
Dry weight	25,8 kg

## Spécifications techniques

Modèle GX 270	
Type du moteur	Moteur à essence monocylindre 4 temps OHV, refroidissement à air, cyl. incliné 25°, arbre de prise de force horizontal, cyl. chemisé en fonte
Alésage x course	77 x 58 mm
Cylindrée	270 cm <sup>3</sup>
Taux de compression	8.5 : 1
Puissance nette	6.3 kW (8.4 HP) / 3 600 tr/mn
Puissance en service continu	4.6 kW (6.2 HP) / 3 000 tr/mn 5.1 kW (6.8 HP) / 3 600 tr/mn
Couple maximum	19.1 Nm / 1.94 kgfm / 2 500 tr/mn
Système d'allumage	CDI numérique avec allumage à avance variable
Système de démarrage	Lanceur à rappel (démarrateur électrique en option)
Cap. du réservoir d'ess.	5.3 l
Consommation de carburant en service continu	2.4 litre(s)/heure - 3 600 tr/mn
Capacité d'huile moteur	1.1 l
Dimensions (L x l x H)	381 x 428 x 422 mm
Poids à sec	25,8 kg

## Spezifikationen

Modell GX 270	
Motortyp	Luftgekühlter 1-Zylinder 4-Takt OHV Benzinmotor, um 25° geneigter Zylinder, horizontale Kurbelwelle, Gußeisen Buchse
Bohrung x Hub	77 x 58 mm
Hubraum	270 cm <sup>3</sup>
Verdichtung	8.5 : 1
Netto-Leistung	6.3 kW (8.4 HP) / 3 600 min <sup>-1</sup>
Max. Dauerleistung	4.6 kW (6.2 HP) / 3 000 min <sup>-1</sup> 5.1 kW (6.8 HP) / 3 600 min <sup>-1</sup>
Max. Netto-Drehmoment	19.1 Nm / 1.94 kgfm / 2 500 min <sup>-1</sup>
Zündsystem	Digitale CDI-Zündung mit variablem Zündzeitpunkt
Starter	Zugstarter (Elektrostart Sonderausstattung)
Tankinhalt	5.3 Liter
Benzinverbrauch bei Dauerleistung	2.4 L/h - 3 600 min <sup>-1</sup>
Motorölkapazität	1.1 Liter
Maße (L x B x H)	381 x 428 x 422 mm
Trockengewicht	25,8 kg

## Dati tecnici

Tipo GX 270	
Tipo di motore	Motore monocilindrico OHV ad albero orizzontale, ciclo otto, 4 tempi, cilindro inclinato di 25° raffreddamento ad aria forzata, cilindri in ghisa
Alesaggio x corsa	77 x 58 mm
Cilindrata	270 cm <sup>3</sup>
Rapporto di compressione	8.5 : 1
Potenza netta	6.3 kW (8.4 HP) / 3 600 giri/min
Potenza nominale continua	4.6 kW (6.2 HP) / 3 000 giri/min 5.1 kW (6.8 HP) / 3 600 giri/min
Coppia massima	19.1 Nm / 1.94 kgfm / 2 500 giri/min
Accensione	Digital CDI con anticipo accensione variabile
Avviamento	Autoavvolgente (elettrico opzionale)
Capacità serbatoio	5.3 Litri
Consumo di combustibile alla potenza continuativa	2.4 Litri/ora - 3 600 giri/min
Capacità coppa olio	1.1 Litri
Dimensioni (Lu x La x A)	381 x 428 x 422 mm
Peso a secco	25,8 kg

## Specificaties

Model GX 270	
Motortype	Luchtgekoelde 4-takt OHV benzinmotor, 25° hellende cilinder, horizontale uitgaande as, gietijzeren cilinderbus
Boring x slag	77 x 58 mm
Cilinderinhoud	270 cm <sup>3</sup>
Compressie	8.5 : 1
Netto vermogen	6.3 kW (8.4 HP) / 3 600 t/min
Continu nominaal vermogen	4.6 kW (6.2 HP) / 3 000 t/min 5.1 kW (6.8 HP) / 3 600 t/min
Max. netto koppel	19.1 Nm / 1.94 kgfm / 2 500 t/min
Ontsteking	Digitale CDI met variabel ontstekingstijdstip
Startsysteem	Repeteerstarter (electrische start optioneel)
Tankinhoud	5.3 Liter
Brandstofverbruik aan cont. nominaal vermogen	2.4 l/u - 3 600 t/min
Motoroliecapaciteit	1.1 Liter
Afmetingen (L x B x H)	381 x 428 x 422 mm
Drooggewicht	25,8 kg

## Specificationer

Modell GX 270	
Motortyp	Luftkyld 4-takts bensinmotor med överliggande ventiler, 25° lutande cylinder, Horisontal axel, cylinderfoder i gjutjärn
Cylinderdiameter x slaglängd	77 x 58 mm
Slagvolyum	270 cm <sup>3</sup>
Kompressionsförhållande	8.5 : 1
Netto effekt	6.3 kW (8.4 HP) / 3 600 varv per minut
Rek. kontinuerlig effekt	4.6 kW (6.2 HP) / 3 000 varv per minut 5.1 kW (6.8 HP) / 3 600 varv per minut
Max. netto vridmoment	19.1 Nm / 1.94 kgfm / 2 500 varv per minut
Tändsystem	Digital CDI med variabel tändning
Startsystem	Startapparat (elektrisk start som tillval)
Tankvolyum	5.3 Liter
Bränsleförbrukning vid kontinuerlig märkeffekt	2.4 L/tim - 3 600 varv per minut
Oljevolyum	1.1 Liter
Dimensioner (L x B x H)	381 x 428 x 422 mm
Torrsvikt	25,8 kg

# HONDA

ENGINES

**Honda Europe NV**  
EUROPEAN ENGINE CENTER  
Langerbruggestraat 104  
B-9000 Gent  
TEL: + 32 (0)9 250 12 11  
FAX: + 32 (0)9 250 14 24

[www.honda-engines-eu.com](http://www.honda-engines-eu.com)

### Honda Engines - France

Honda France SAS • Parc d'Activités de Pariest • Allée du 1<sup>er</sup> Mai, BP 46 • Croissy Beaubourg • F-77312 Marne-la-Vallée Cedex 2  
TEL: + 33 (0)1 60 37 30 16 • FAX: + 33 (0)1 60 37 33 66

### Honda Engines - Germany

Honda Deutschland GmbH • Sprendlinger Landstraße 166 • D-63069 Offenbach/Main  
TEL: + 49 (0) 69 8309 (0) 365 • FAX: + 49 (0) 69 8309 (0) 128

### Honda Engines - Italy

Honda Logistic Centre Italy S.p.A. • Via Strà 153-154 • I-37030 Colognola ai Colli (VR)  
TEL: + 39 045 6173341 • FAX: + 39 045 6151270

### Honda Engines - Sweden

Honda Nordic AB • Box 31002 • SE-200 49 Malmö  
TEL: + 46 40 38 07 00 • FAX: + 46 40 38 07 05

### Honda Engines - United Kingdom

Honda Logistics Centre (UK) Ltd. • Viscount Way, South Marston Park • Swindon SN3 4TN, UK  
TEL: + 44 (0)1 455 559429 • FAX: + 44 (0)1 455 559428

### Honda Engines - Russia

Representative office of Honda Europe in Russia  
Building 1, Pridorozhnaya Street, Sharapovo settlement, Marushkinsky District • 143350 Moscow, Russia  
TEL: + 7 (495) 745 2080 • FAX: + 7 (495) 745 2081

All specifications are subject to change without notice.  
Les caractéristiques techniques peuvent être modifiées à tout moment et sans préavis.  
Specifikationer kan ändras utan föregående meddelande.

Le specifiche sono soggette a cambiamento senza preavviso.  
Die Spezifikationen können ohne Vorankündigung geändert werden.  
Alle technische specificaties kunnen op elk ogenblik en zonder kennisgeving gewijzigd worden.

Ref. EEC - TS 7754 Nov. 2012 - GX 270

[honda.com](http://www.honda.com)